

NAND Gate Logic

Grades: 4-5

Objective: Students will learn how to construct all possible circuits out of NAND gates.

Time: 40 minutes

Materials:

For each group of 4 students, have one set of:

- 1 Battery (AA, 9 Volt, etc, but low voltage so nobody gets hurt)
- Alligator clip wires
- 5 NPN NAND gates
- lamp

Overview:

Your mentor will explain the operation of a NAND gate. You find that you need to construct digital logic circuits, but the only type of logic gate you have is a NAND gate! Construct each of the other logic circuits via combinations of NAND gates.

Scientific Background:

It is well known that all possible digital logic circuits can be designed solely through the use of NAND gates. This fact relies on the demonstration that combinations of NAND gates can produce the same functionality as any of the other AND gates.



NAND Gate

A	B	Out
0	0	1
1	0	1
0	1	1
1	1	0

Procedure:

1. Demonstrate the operation of the NAND gate and confirm the truth table with the kids.
2. Assign each group a different Logic gate (AND, OR, NOT) and ask them to build them out of NAND gates. After 10 minutes, rotate the groups so that after 30 minutes each group has tried to construct each type of logic gate.
3. Compare designs among the groups. *Efficient designs are listed here* (http://imrl.usu.edu/OSLO/technology_writing/005_008b.htm, 8/1/06)

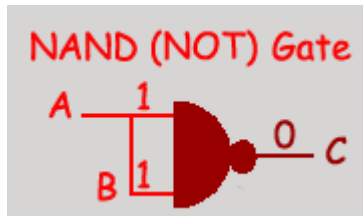

If lead A is tied to lead B, the NAND Gate becomes a NOT gate.

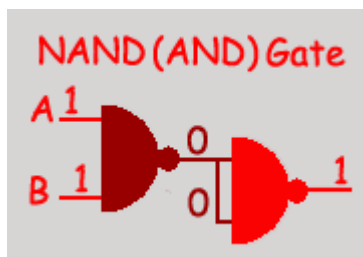

A NAND Gates plus a NOT Gate creates an AND Gate.

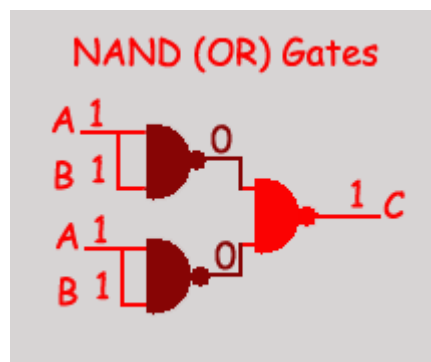

Two NOT Gates plus a NAND Gate creates an OR Gate.

Additional Questions/Discussion Points:

Discuss with the kids the importance of NAND gates. Because they are cheap to produce, microprocessors are often built purely out of NAND gates.

Discuss with kids if they think any other logic gates can be considered universal? *Yes, the NOR gate, however this gate has not been introduced to them.*